



**ANTI WAVE**

AntiWave manufactures recreational and competitive pool lane lines & water polo goals. AntiWave pool products are built to last and offer industry leading performance and functionality.

**Product Catalog**

# INDEX



ANTIWAVE

01	INDEX
02	ABOUT
03	WHY
04	QUALITY
05	COMPETITIVE RACING LANES
09	WATER POLO GOALS
19	WATER POLO FIELD OF PLAY
20	LANE STORAGE
21	BACKSTROKE START LEDGES
23	ULTIMATE STORAGE REEL
24	GREEN SOLARGUARD LANE LINE REEL COVER
25	WATER POLO BALLS
26	CONTACT



# ABOUT

## ANTI WAVE

Anti Wave was founded in 1971 by former professional WaterPolo player and 2017 FINA Masters 70+ Goalie, Anti Kajlich. Our equipment was first selected for the 1972 Olympic Games in Munich and the 1st World Aquatics Championships in Cali, Colombia in 1975. Since then, Anti Wave has led the world in product innovation and development, with our products featured in numerous Olympic Games, including the 2000 Sydney Games, where 15 World Records were broken using our equipment. Our products have also been showcased in over 50 internationally recognized events.

Today, Anti and his son Anton continue to design, innovate, and produce the world's best aquatic sports products. We have licensed production in eight countries and export to over 150 countries worldwide. Anti Wave is committed to expanding our reach and providing top-quality aquatic sports equipment globally.

At Anti Wave Americas, we mold and assemble lanes at our Constantine, MI plant and import WaterPolo products from our regional partners. We look forward to serving you with the best in aquatic sports equipment.

# WHY



## ANTIWAVE

Global: Widest global availability

Durability & Quality: Industries best 3-year Warranty! World leading durability and product quality, original innovative designs.

Compliant with FINA/LEN Regulations

Innovation: Industry leading innovation and development. Largest selection of lane line colors!

Ultimate Reliability: Designed and tested to tough Australian conditions for ultimate reliability

Global Service: Comprehensive global network of Authorized Resellers and Distributors ensure best service

# QUALITY



ANTIWAVE

AntiWave Maximum and ForeRunner racing lanes, and the Supertensioner are manufactured and assembled at our factory in Constantine, Michigan. All other kits and components are produced specifically for AntiWave under strict quality supervision.

We proudly offer a 3-year warranty on all AntiWave products.

If you encounter any issues, please contact the dealer who sold you the product. The dealer will then coordinate with AntiWave to resolve the issue promptly and to your satisfaction. All warranty claims must be processed through your dealer. We cannot accept returned goods without prior approval. The warranty covers defects in manufacturing or part quality, or omissions attributable to AntiWave. Damage incurred during transit from our plant to the final destination is the responsibility of the freight company. The warranty does not cover normal wear and tear.



We are proud to offer the most comprehensive warranty program in our industry, unmatched by any other supplier of non-fitted competitive aquatic equipment. Antiwave is the official sponsor of USA water polo for Goals and field of play and a FINA compliant supplier.



## Competitive Racing Lanes



*AntiWave Racing Lanes have been used in multiple Olympics, and selected by universities and clubs throughout the world. The unique lane and disc design provides advanced wave quelling technology while having a sporty and savvy appearance. AntiWave's Maximum Racing Lanes are the world's most effective, proven by their use in the 2000 Sydney Olympics where 15 World Records were set. The Australian Olympic team coach called the pool "a virtual millpond."*



### Maximum 6" Disc – Racing Lanes

Using hydromatic propulsion, these lanes disperse waves along the lane line to create perfectly tranquil water.

- Equipped with the unique Supertensioner
- Made of UV-stable resin plastic to prevent fading and deterioration from sunlight.
- Available in standard or custom lengths.
- Improves swimming performance
- Proudly made in the U.S.

## Competitive Racing Lanes

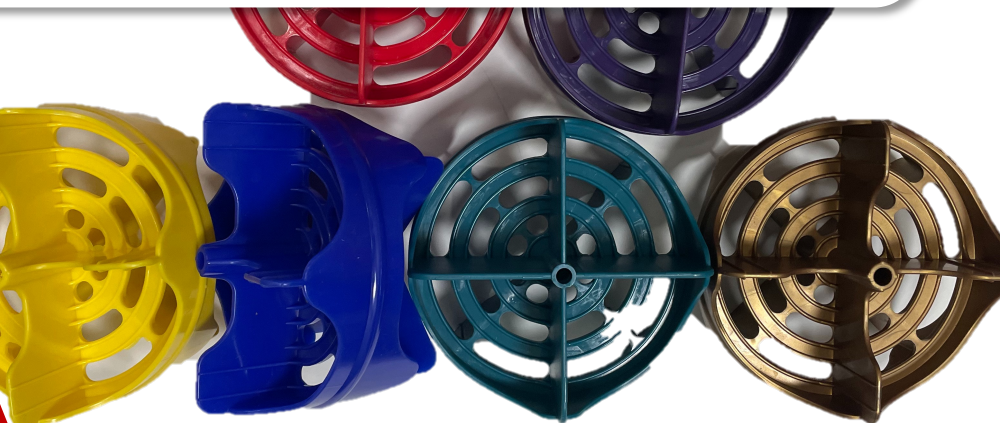

### Forerunner 4.75" Disc – Racing Lanes

Our top-selling AntiWave ForeRunner Racing Lanes are modeled after the successful 6-inch Maximum Lanes used in the 2000 Sydney Olympics. Using hydromatic propulsion, these lanes disperse waves along the lane line to create perfectly tranquil water.

- Equipped with the unique Supertensioner
- Made of UV-stable resin plastic to prevent fading and deterioration from sunlight.
- Available in standard or custom lengths.
- Improves swimming performance

# Competitive Racing Lanes

## AntiWave Supertensioner

The Supertensioner, unique to AntiWave, is the original turnbuckle tensioning device that sets the standard. Its ease of use and rugged design make it a state-of-the-art solution compared to traditional drum and ratchet systems.

Easy to adjust. Tension or release the lane line with a few twists of the wrist—no wrench needed. It's sleek, stylish, and trouble-free, unlike the bulky old-style ratchet systems.

Accidental release-proof. Unlike other ratchet devices, the Supertensioner's lock-nut feature prevents accidental tripping and cable messes.

Cable-friendly. The Supertensioner's rotating body prevents cable fraying, enhancing safety and eliminating the need for plastic-coated cables.

Time-saving. With easy installation and clear instructions, reconfiguring the pool takes minutes. The Supertensioner fits any lane, making upgrades and replacements simple.



- Dimensions: 14" half-way extended (as shipped)
- The tensioner can be adjusted 3" in either direction, therefore it can be 11" fully condensed or 17" fully extended.
- Made of UV stable resin plastic which reduces the risk fading and deterioration caused by long term exposure to sunlight.
- Comes fitted as standard on all Anti Wave Maximum and ForeRunner lanes.
- Can be used on existing lane lines.



# Competitive Racing Lanes

## COLORS

### Standard Colors – 3 days

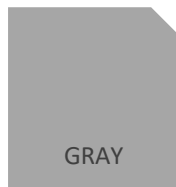
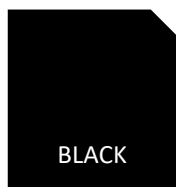
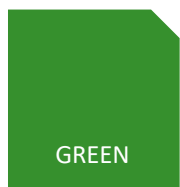
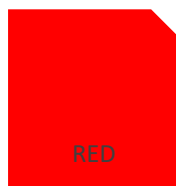

### Specialty Colors – 7 days



Do not see the color you want? We can create custom colors. Inquire about color, cost & lead-time.

# Water Polo Goals

## AWE312 – 20M Inflatable Water Polo Backstop

The Polo Inflatable backstop provides protection of deck equipment such as starting blocks and fittings from wayward shots during water polo training and competition. The Backstop also provides an opportunity for display of advertising and competition branding. Includes provisions for banners across the front edge, as well as provisions for banners on the top side of the Backstop. Custom advertising Banners are available as an optional extra. Securely held into position by connection to the Polo Field lanes, includes attachment points on each end.



### Specifications

- Produced from Heavy Duty PVC Coated Nylon material for durability and puncture resistance.
- Inflated Overall Dimensions Length 20m x Width 2m x Height 0.5m
- Includes 240V Air Pump and Storage Case.
- Includes Velcro attachment points for banner and advertising attachment (Banners not included).
- Contact us for custom sizes and dimensions to suit your competition or training facility.

# Water Polo Goals

## AW0674 – FlipFloat Senior Folding Goal 750

Formerly listed as the FlipFloat. This product is a full-size competition floating polo goal, dimensionally the same size as the very popular Club Goal, with the added benefit that IT FOLDS FLAT FOR STORAGE and weighs only 85 lb. Meets all national and international specifications and is easy to erect and fold down; just pull the Rear Arms out of their sockets, and the Front Frame folds down onto the Float Panels. That's it!! Once folded, the goal can be carried easily by two people.

- All metal parts are made of durable white powder-coated aluminum, hardware is stainless steel. The flotation panels are hand-laid fiberglass, and the net is of tough polypropylene cord, knotted at every intersection.
- Is supplied in kit form to minimize freight costs.
- Can be assembled in approximately one hour by two people; each goal comes with a detailed assembly instruction sheet, also available below.
- Comes with a limited 3-Year Warranty.

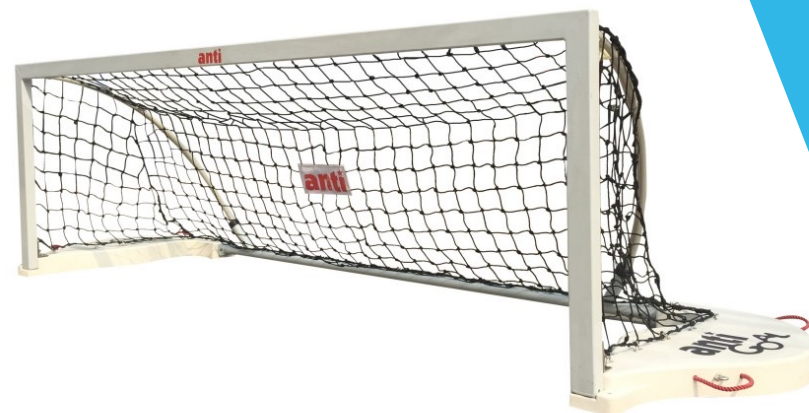

### Information regarding FINA Specification

- In 2015 FINA had rule change on the distance between the two goal side anchors (the penalty exclusion zone) . This area was increased from 750 mm (29.5 in) to 1080 mm (42.5 in). The majority (99%) of existing pools do not want to redrill the holes for anchors on the sides of pools from existing 750mm apart to new FINA 1.08m distance. Most customers, clubs etc. around the world continue to order the 750 goals.
- The FlipFloat Senior Folding Goal 750 and the Odyssey Anti Pro Goal 750 currently offered both support the 750 configuration. These goals do however meet the Front Frame FINA specification.
- If FINA Spec Competition Goal is required, then we can provide pricing and lead time of offering either AWE330A Senior Folding Goal 1080 or AWE331 Anti Pro Goal 1080.
- We can also provide price and lead-time on AWE330B ALU Adaptor Bars -080mm (2pc), converts existing AWE330 SNR Folding Goal 750 to have an extra 1080mm Anchor point.



# Water Polo Goals



## AWE393 – Global Anti Goal – JNR Conversion Kit

The Anti Wave JNR Conversion Kit provides a simple and innovative solution for clubs to convert their existing SNR & Anti Goals to JNR Goal face dimensions in a matter of seconds. The Kit is secured to the Goals with supplied SS316 Wingnuts and once fixed firmly in place the Kit converts the SNR dimension Goals (3m x 0.9m Goal face) to JNR Dimension Goal Face.

- Quickly and easily converts an Anti Wave SNR Folding Goal or Anti Pro Goal to JNR Goal face dimensions.
- Installs in a matter of seconds via SS316 quick release wing nuts, installs into the existing Goal face channel.
- Durable HD PE Foam elements convert the goal face to the JNR Goal dimensions.
- Packs away into small volume, easy to carry and store.
- All fittings are non-corrosive marine grade Nylon, and SS316.
- HD PE Foam Elements ensure no sharp corners or hard edges, safe for use with all ages.
- Kit includes all parts required to convert each 1pc Goal.
- Converts Goal face from 3m x 0.9m (SNR) to 2.6m x 0.9m (JNR).

# Water Polo Goals

## Inflatable Water Polo Goals

**Junior: AWE493, Beach: AWE494, Senior: AWE495**

The Global Inflatable Goal Range blends high quality, durable materials and components with a compact and easy to transport and lightweight design. A durable and affordable inflatable option for polo clubs and pools for both training and competition. Models include SENIOR Polo, BEACH Polo, and JUNIOR Polo sizes; catering for Adult clubs as well as the very popular international FINA Beach Polo & also Jnr Habawaba Youth Polo competition formats. The goals include a tough Oversized PVC Carry Bag and High-Volume Foot Pump. The Bag has enough space for a few extra balls and caps to be carried. Available in 3 Sizes: SNR Inflatable Goal 9.84' L x 2.95' W x 3.93' D (FINA), White with Red tape, BEACH Inflatable Goal (FINA) 8.20' L x 2.62' W x 3.60' D, White with Yellow, and JNR Inflatable Goal 7.05' L x 2.46' W x 3.28' D, White with Green (HabaWaba size).

### Specifications

- Heavy Duty marine grade PVC coated nylon material with SS316 Fittings.
- 2pc Oversized SS316 D-rings located on each side of the Goal for simple connection of the Goal Line tethers from the side of the pool, or from behind to pool edge or bulkhead.
- Tough & durable oversized 9.84inch Heavy Duty & Reinforced Machine Seam Welded PVC Coated Nylon Tubes.
- Includes High Volume heavy-duty foot pump (fits in bag) Puncture repair material also included.



- HD Carry bag is designed to be slightly oversized to easily and quickly return the deflated goals to the bag, and to carry both the goal and foot pump, as well as few polo balls and players caps.
- Black Net included, removable and replaceable. Net is Pre-installed on the Goals and available to be purchased as a replacement item if needed.
- Designed and tested in Australia to meet the needs of harshest AUS conditions and requirements.

# Water Polo Goals

## Global Anti Goals

Available in 1.2m – AWE392 and 1.4m– AWE394 goal depths.

The 2021 release of the 'Global Anti Goal' represents the culmination of 50 years of experience in Goal innovation, design and production. The Global Anti Goal blends cutting edge materials and production with innovative design, resulting in a durable, full sized Polo Goal, perfectly suited to all Clubs and Polo facilities. The AWE394 is designed for use in top level competition events and pools that require the current FINA regulation side length (1.4m) and side anchor width dimensions (1080mm).

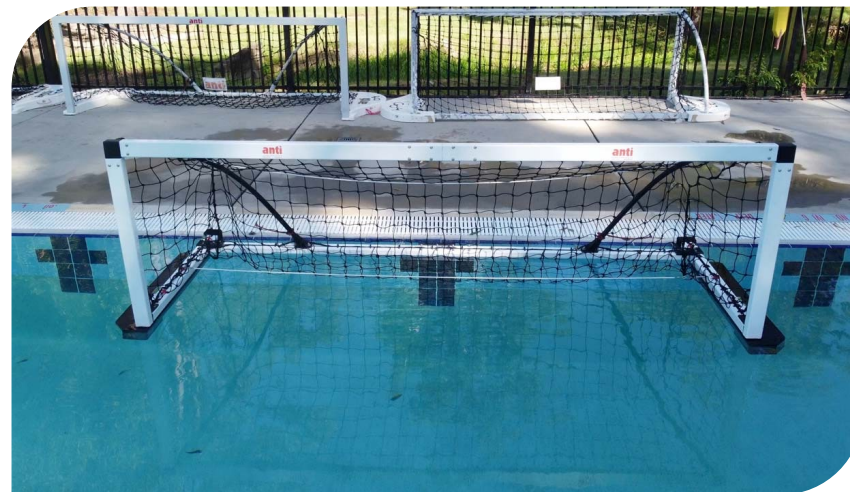

The Goal Training Targets provide shooters with a high visibility target that give a positive audible slap one hit.

- Fabricated from custom marine grade powder coated Aluminum with HD Marine Nylon & SS316 fittings.
- Easily foldable for compact and safe poolside storage.
- Includes Long-Life HD polypropylene cord net.
- Marine Nylon Net Clips ensure simple and secure Net Installation.
- Soft Durable Pool Edge bumpers on rear of frame prevent damage to expensive pool edge and tiles.
- Durable oversized HD PE Flotation elements ensure stability during use, foam elements rest on the pool concourse, preventing damage to pool edge and tiles.
- Open corner net configuration reduces ball rebound.
- PVC Bows allow quick disconnect of lower rear frame to goal top frame for compact folding and low-profile storage.
- Durable, light weight, heavy duty design and construction allowing safe and easy 1 or 2 person pool deck movement.



## Water Polo Goals

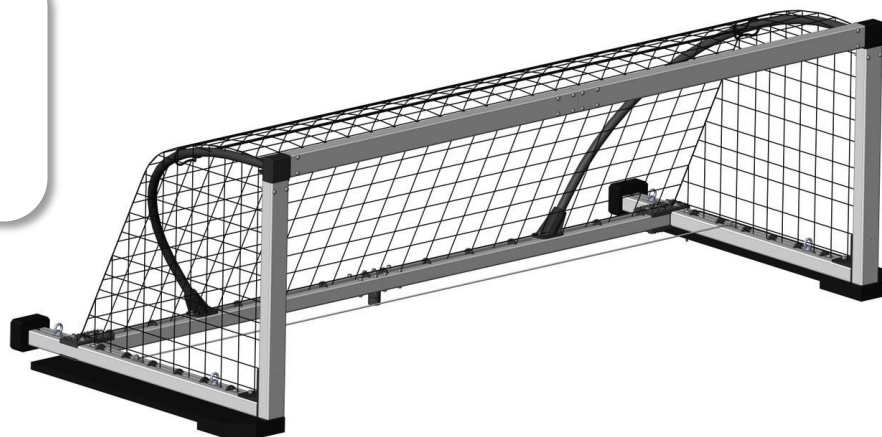

### AWE390 – JNR Global Anti Goal, 2.5 M X 0.8 M

A smaller junior version of our new Global Anti Goal. The JNR Model Goal is designed and produced in Australia to the highest specifications. Compliant with all current FINA JNR Competition regulations. This product blends cutting edge materials and production with innovative design, resulting in a durable, full sized Polo Goal, perfectly suited to all Clubs and Polo facilities.

- Fabricated from custom marine grade powder coated
- Aluminum with HD Marine Nylon & SS316 fittings.
- Easily foldable for compact and safe poolside storage.
- Includes Long-Life HD polypropylene cord net.
- Marine Nylon Net Clips ensure simple and secure Net Installation.
- Soft Durable Pool Edge bumpers on rear of frame prevent damage to expensive pool edge and tiles.
- Durable oversized HD PE Flotation elements ensure stability during use, foam elements rest on the pool concourse, preventing damage to pool edge and tiles.
- Open corner net configuration reduces ball rebound.
- PVC Bows allow quick disconnect of lower rear frame to goal top frame for compact folding and low-profile storage.
- Durable, light weight, heavy duty design and construction allowing safe and easy 1 or, 2 person pool deck movement.
- JNR Model has 2.5m x 0.8m Front Goal Face dimensions.

# Water Polo Goals

## AW0550 – Odyssey Anti Pro Goal 750

Combining unequaled form and function, the Odyssey floating goal is quite simply the finest water polo goal on the market. It has been used in pools around the world since its introduction at the 2000 Sydney Olympics. As the standard for major competition or state-of-the-art facilities, the Odyssey is the only choice.

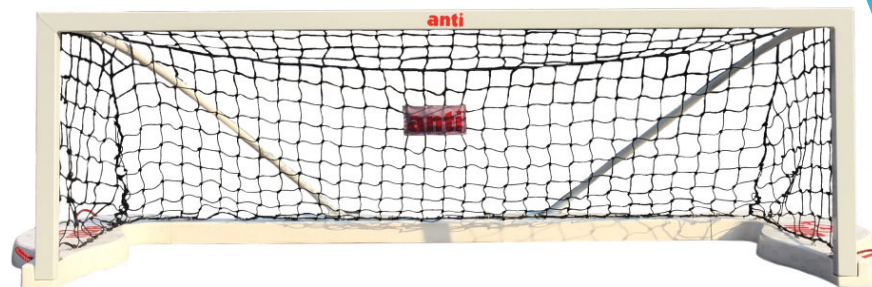

- All metal parts are made of durable white powder-coated aluminum, hardware is stainless steel. The flotation panels are hand-laid fiberglass, and the net is of tough polypropylene cord, knotted at every intersection.
- Is supplied in kit form to minimize freight costs.
- Can be assembled in approximately one hour by two people; each goal comes with a detailed Assembly Instruction sheet.
- Comes with a limited 3-Year Warranty.

### Information regarding FINA Specification

- In 2015 FINA had rule change on the distance between the two goal side anchors (the penalty exclusion zone) . This area was increased from 750 mm (29.5 in) to 1080 mm (42.5 in). The majority (99%) of existing pools do not want to redrill the holes for anchors on the sides of pools from existing 750mm apart to new FINA 1.08m distance. Most customers, clubs etc. around the world continue to order the 750 goals.
- The FlipFloat Senior Folding Goal 750 and the Odyssey Anti Pro Goal 750 currently offered both support the 750 configuration. These goals do however meet the Front Frame FINA specification.
- If FINA Spec Competition Goal is required, then we can provide pricing and lead time of offering either AWE330A Senior Folding Goal 1080 or AWE331 Anti Pro Goal 1080.
- We can also provide price and lead-time on AWE330B ALU Adaptor Bars -080mm (2pc), converts existing AWE330 SNR Folding Goal 750 to have an extra 1080mm Anchor point.

# Water Polo Goals

## AW0672 – Splashball Junior Flippa FloatFlip Goal

The Splash Ball floating goal is a two-thirds size version of our very popular Club goal, with the added benefit that IT FOLDS FLAT FOR STORAGE and weighs 75 lb. The Splash Ball is the ideal recreational goal for kids' games, practice, residential and club pools, or any location where a full-size competition goal is not needed. This goal is also great value for money!

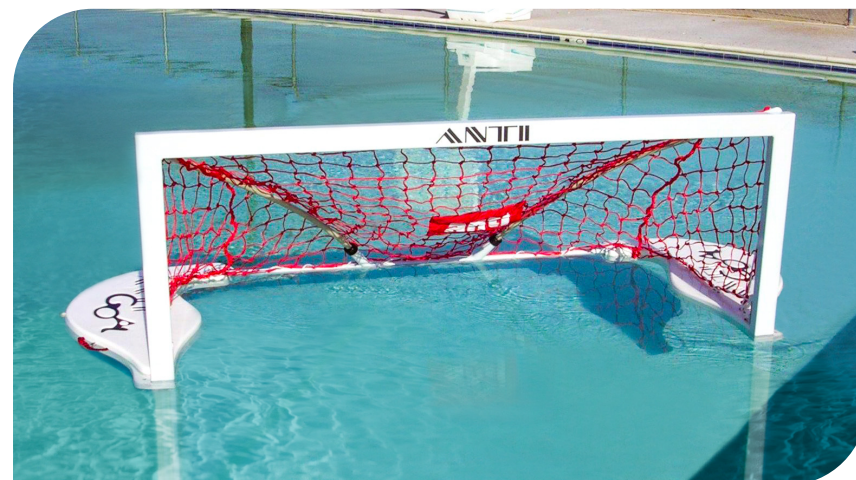

- All metal parts are made of durable white powder-coated aluminum, or stainless steel. The flotation panels are hand-laid fiberglass, and the net is of tough polypropylene cord, knotted at every intersection.
- Is supplied in kit form to minimize freight costs.
- Can be assembled in approximately one hour by two people; each goal comes with a detailed assembly instruction sheet.
- Comes with a limited 3-Year Warranty
- Replacement Net: AW0642 Splashball Junior Flippa Black Net ONLY available



# Water Polo Goals



## AW0616 – Universal Wall Goal – Long

The Universal Wall Goal is the ideal choice for competitive water polo at any level, from local to international pools. It is rugged, stylish and very cost effective.

- This is the goal that has been primarily supplied to USA market for several years.
- All metal parts are made of durable white powder-coated aluminum for extra protection.
- The net is of tough polypropylene cord, knotted at every intersection.
- The canvas is a durable plain-woven fabric with a top layer of PVC that seals the threaded bottom layer and makes for a smooth and glossy surface.
- The Rear Arms are fully adjustable horizontally (up to 36") and can be adapted to most existing deck anchor locations. Two deck anchors are included with the goal.
- Is supplied in kit form to minimize freight costs.
- Can be assembled in approximately one hour by two people; each goal comes with a detailed assembly instruction sheet.
- Comes with a limited 3-Year Warranty.
- Dimensions 124" x 66.03" x 23.62" deep ( 10.3 ' x 5.5 ' x 1.96 ' )

# Water Polo Goals



## AWE328 – Universal Wall Goal – Short

The Universal Wall Goal is the ideal choice for competitive water polo at any level, from local to international pools. It is rugged, stylish and very cost effective.

- The Anti Wave Universal Wall Goal is designed to fit to a raised EndWall or on a Moveable Bulkhead.
- Configured to get the most out of restricted space and is excellent for training, social matches and for competition below the international level.
- The Short Wall goal has dimensions closer to FINA Official size, better suited for training where mounted against Bulkhead.
- Fabricated from powder coated aluminum extrusions and hand-laid fiberglass for durability and strength.
- Net is tough polypropylene cord, knitted at every intersection.
- Dimensions 124" x 23.62" x 40.35"
- Comes with Black Net and Blue Canvas

# Water Polo Field of Play

## Field Lane Lines

The Anti Polo Field combines the best of Anti Wave's Polo products to create a Polo field that is at the forefront of design and quality internationally. Marked by the famous AntiWave Lanes to minimize water disturbance and wash effect on the players.

- Choose from Maximum (6") or Forerunner (4.75") Discs.
- When selecting Goal Tether Lanes, Forerunner 4.75" discs have less chance of breakage if hit by a ball.
- We produce field lanes for a variety of length pools.
- Come with a limited 3-Year Warranty.



# Lane Storage

## AW0560 – Swim Lane Caddy

The Anti Wave Lane Caddy provides for safe and quick removal and installation of AntiWave swimming racing lanes.

The Lane Caddy is designed to be quickly installed onto the pool deck and allows for smooth and unhindered movement of lanes that would otherwise be damaged by the sharp pool edge.

The perfect way to protect your AntiWave Racing Lanes from unnecessary damage.



- Hooks over the pool edge to enable easy removal of lanes.
- Produced from top quality hand laid fiberglass for years of use.
- One Lane Caddy will fit one AntiWave lane at a time.
- Comes with a limited 3-Year Warranty.

### Specifications:

- Material: Fiberglass
- Overall Dimensions: 605 mm x 425 mm x 445 mm
- Shipping weight: 3.25 KG
- Shipping CBM Total: 0.07m<sup>3</sup>

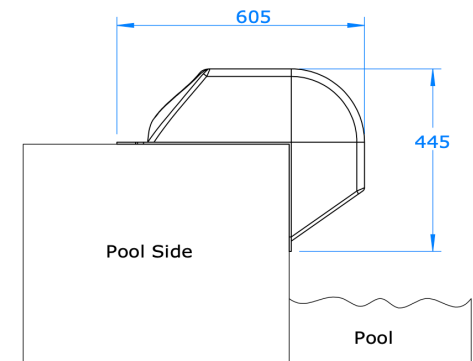
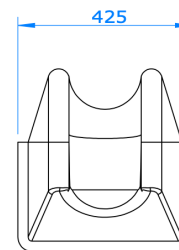



# Backstroke Start Ledges

## AWE351 – Backstroke Start Ledges

The Anti Wave Backstroke Start Ledges are a simple and practical backstroke starting device for swimmers to perform top performance backstroke starts. Suitable for training and competition, the Ledge assists swimmers with the fastest possible starts by providing positive traction on the pool wall. The Backstroke Start Ledge has a simple manual height adjustment and is suitable for connection to all standard starting blocks including all Anti Wave Blocks. Meets all FINA regulations, developed in consultation with Australian Backstroke Swim team members, the Ledge is simple to adjust from in the pool by the swimmer or on the pool deck by the coach.

To Receive a formal specification, assembly instructions, or CAD please contact us directly.



## Specifications

- Compatible with all standard block types, and adjustable to suit a range of swimmers needs including Masters as well as Top Competition Swimming and Training.
- Marine grade anodized aluminum body with non-slip surface, Marine Nylon Protector End Caps and Marine Polyester webbing & SS316 Cam Buckle.
- Rear of ledge includes custom PVC bumper protection to protect pool wall and tiles from scratching.
- Five separate height settings to suit each swimmers needs using simple and durable Marine StayPut and Eyelet system.
- Adjustable on the pool by the swimmer while in the water, or by the coach on the pool deck.
- Meets FINA FR 2.10 Regulations, suitable for FINA Events.

## Includes:

- BS Ledge Non Slip Body with CrocGrip Tape on upper
- Heavy Duty rated Straps and Wedge Attachment Pad
- Nylon Protector pad on rear of Ledge to protect tiles
- 2pc Nylon Strap Holders with SS316 Screws
- 1pc Nylon Locating Pin with SS316 Screws
- Enough excess strap for a variety of block types
- Each Ledge packing individually in closed sleeve

# Ultimate Storage Reel

## AW0615 Ultimate Storage Reel

AntiWave's Ultimate Storage Reel is among the largest capacity lane line reels on the market and is certainly the most reasonably priced. It is an easy, light weight, and cost-effective solution to storing your racing lanes.

- Storage Reel Size: 72" high x 90" long x 48" wide and Weight of 106 lbs.
- Made of durable white powder-coated aluminum.
- All four wheels independently lock and rotate.
- 6-inch diameter center spindle to reduce potential damage to the lane line discs.
- Easy to assemble.
- Comes with 3-Year Warranty.
- Discount offered for purchase of certain quantity of lane lines along with Ultimate Storage reel. Ask your Dealer for details.
- Please do not store your Storeel outside in cold weather (below freezing). Water can get into the assembly and cause warpage and expansion. We cannot be responsible for this damage.
- Please ensure that swimmers and spectators do not place undue weight on reels or use them for anything other than storing lanes. We cannot be responsible for damage in these cases.
- Storage of lanes (Quantities of lanes denoted in parentheses)
  - Forerunner 4.75" lanes – (9) 60' lanes, or (8) 75' lanes ,or (7) 25M lanes, or(3) 50M lanes – Total of 492 linear feet up to 540 linear feet
  - Maximum 6" lanes – (6) 60' lanes, or (5) 75' lanes, or (4) 25M lanes, or (2) 50M lanes – Total of 328 linear feet up to 360 linear feet



# Green Solarguard Lane Line Reel Cover

## AW0619 – Green Solarguard Lane Line Reel Cover

Protect your Anti Wave racing lanes with the Solarguard Storeel cover.

- Produced from top quality UV resistant Solarguard material for long life and durability.
- Comes with a limited 3-Year Warranty.



# Water Polo Balls

## AW0700 Mens, AW0710 Womens & AW0720 Junior Size Water Polo Ball

Anti Wave Premium Water Polo Balls are produced to the highest specifications and are suitable for both training and competition. Available in Size 3, 4 and 5, and with a fresh range of color combinations for excellent visibility. Featuring premium materials for ultimate durability.



### Specifications

- Premium grade, highly durable PoloGrip Ball with excellent visibility in all playing conditions.
- Developed in collaboration with top polo clubs and teams around the world to suit all conditions.
- Size 3 PoloGrip Training and Competition Ball is the official size for boys and girls 12U water polo
- Size 4 PoloGrip Training and Competition Ball is the official size for Women's training and competition and meets the specifications as set out by LEN, FINA, and World Aquatics for Water Polo.
- Size 5 PoloGrip Training and Competition Ball is the official size for Men's Water Polo and meets the specifications as set out by LEN, FINA, and World Aquatics for Water Polo. Now available in all countries with discounted air Carrier freight available. Please contact us for details on how to order in your country.



# CONTACT

## **AntiWave Pool Products**

485 Florence Road

Constantine, MI 49042

Tel: 1. 269.433.7034 | Fax: 1.269.435.6935

About AntiWave: <https://antiwave.com>

Where to Buy: <https://antiwave.com/where-to-buy/>